

Model PTU-D48 E-Series

High-Performance Pan/Tilt Unit

Precise, Programmable, Rugged

Real-time control, built-in Ethernet

The PTU-D48 E-Series is a high-performance real-time positioning system for payloads up to 15 Lbs.

The PTU-D48 E Series pan/tilt offers very high precision positioning and speed control. The stepper motor/worm gear design supports micro-stepping and is based on a rigid bearing and mechanical design to ensure solid repeatable motion. The unit is highly programmable with user parameters for range of motion, speed, acceleration, power consumption and more. The real-time command interface supports advanced applications such as video tracking. The low parts count, and highly integrated design provides unsurpassed system reliability.

The PTU-D48 E Series supports any type of single or multi-part payload through a flexible bracketing system of top and/or side mounting. It has been designed to be simple to integrate. The PTU-D48 E Series is an open platform that provides the flexibility needed while minimizing your development and integration effort.

The PTU-D48 E Series has been proven in a wide range of mission-critical applications for positioning of cameras, lasers, antennas, or other instruments in both fixed and mobile environments. It is designed for high duty cycles and reliable operation 24/7 in harsh all-weather environments. The PTU-D48 E Series will help ensure your project is completed on-time and right the first time.



Key features include:

- Large payload capacity to 15 Lbs
- Extremely precise positioning (to 0.006° with microstep)
- Wide range of pan speeds 0.006°/sec to 100° for smooth, precise control
- 360-continuous pan (with slip-ring option)
- Precise, real-time control of position, speed and acceleration
- Rigid worm gear design (no belts/pulleys) provides steady positioning in windy environments
- Solid and vibration-tolerant for vehicle-mounted applications
- Single connector for power, control, payload signals
- Flexible payload mounting (to or sides)
- Fully sealed for outdoor/marine applications (IP67)
- Wide temperature range with no heater required
- Wide-range DC power input (12VDC to 30VDC) with battery-friendly power controls
- Precise digital encoders
- Multiple control interfaces: RS-232/485/422 and Ethernet
- Multiple protocol command interface: FLIR-MCS, Nexus, Pelco-D

Available options include:

- Payload brackets (top, side)
- Alternate colors/finishes
- Inertial stabilization
- Geo-pointing

About the E-Series Pan/Tilt Units

The latest evolution of MCS pan-tilts incorporates a powerful 32-bit core electronics platform and real-time operating system to deliver superior motion control fidelity and improve performance. The E-Series architecture includes:

- Increased command rates, reduced jitter
- Advanced microstep control
- Digital encoders for closed-loop control
- User-programmable ranges of motion
- Integrated Ethernet and Web interfaces
- Slip-ring for 360° continuous pan
- On-board stabilization (with ISM option)
- On-board geo-pointing (with GPM option)
- CE mark, FCC, RoHs compliant



Surveillance



Military



Remote Sensing



Robotics



Maritime



Antennas



Motion Control Systems

Model PTU-D48 E-Series

Technical Specifications

Pan/Tilt Performance

	Side Mount	Top Mount
Max. Payload	15 lb	10 lb
Pan Speed Range¹	0.006°/sec - 100°/sec	0.006°/sec - 100°/sec
Tilt Speed Range	0.003°/sec - 50°/sec	0.003°/sec - 50°/sec
Resolution - Pan	0.006°	0.006°
Resolution - Tilt	0.003°	0.003°

¹ Unloaded. Maximum speed may depend on exact payload configuration and input voltage.

Pan/Tilt Features

Max. Tilt Range	Programmable up to +30° to -90° from level (120° range)
Max. Pan Range	Programmable up to +/-188° range, nx360° with slip-ring option
Duty Cycle	Up to 100% duty cycle
Acceleration/Deceleration	On-the-fly speed and position changes

Power Requirements

Input Voltage	Unregulated 12-30 VDC (fastest performance & torque @ 30 VDC)
Input Protection	Over-voltage/over-current protection meets MIL-STD-1275D
Power Consumption (Measured at 30VDC with loaded axes. May vary with application.)	19.8W (Low move power mode) 26.4W (Regular move power mode) 34.5W (High move power mode) 3.3W (Hold power off mode)

Connections & Communications

Base Connectors	PRIMARY: Connector: 32-pin (MIL-C-26482) Includes: PTU-Power (3c) - 12-30 VDC + shield PTU-Control (7c) - RS-232 (3c) and RS-485/-422 (4c) Ethernet (4c) pan/tilt configuration/control Payload Pass-Through (9-12c)
Payload Signal Pass-Through	Power (2c): 30 VDC max. @ 3 A Video-1 (2c): NTSC/PAL/RS-170 Video-2 (2c): NTSC/PAL/RS-170 High-Speed Pass-Through (4c): capable of 10baseT Other (3c): 30 VDC max. @ 1 A Connector: 19-pin (MIL-C-26402)
Computer Controls	RS-232, RS-485/422, Ethernet
Control Protocols	DP (ASCII, Binary), Pelco-D (option), Nexus-compatible

Mechanical

Weight	< 12 lbs (not including brackets)
Dimensions	10.46"(h) x 6.84"(w) x 5.45"(d) (with top bracket)
Payload Mounting	Side and/or top
PTU Mounting	Pedestal
Material	Aluminum

Packaging & Environmental

Standards	Designed to IP67
Operating Temperature	-30°C to 70°C (no heaters)
Humidity	100% relative humidity, non-condensing
Ice (Operating)	Sustained operation with 0.25" ice buildup
Dust/Sand (Operating)	Sustained exposure to blowing dust/sand
Wind/Rain/Fog	IP67
Salt Spray	MIL-810F Salt Spray
Color/Finish	Black anodized and powder-coated; custom colors/finishes available
EMI Certifications	CE Mark and FCC Part 15, Subpart B, Class A
Certifications	RoHS Compliant

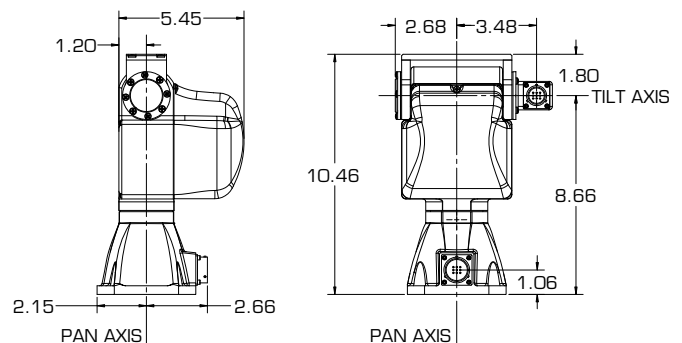

SAN FRANCISCO

FLIR Systems, Inc.
890C Cowan Rd.
Burlingame, CA 94010
USA
PH: + 1 650.692.3900 (Sales)
FX: + 1 650.692.3930
www.FLIR.com/MCS
mcs@flir.com

PORTLAND

CORPORATE HEADQUARTERS
FLIR Systems, Inc.
27700 SW Parkway Ave.
Wilsonville, OR 97070
USA
PH: + 1 650.692.3900 (Sales)

SANTA BARBARA

FLIR Systems, Inc.
70 Castilian Dr.
Goleta, CA 93117
USA
PH: + 1 650.692.3900 (Sales)

THE NETHERLANDS

FLIR Systems BV
Charles Petitweg 21
4847 NW Teteringen - Breda
The Netherlands
PH: +31 (0) 765.794194

©2011 FLIR Systems, Inc. Specifications are subject to change without notice, check our website: www.flir.com/mcs. 1003-248 (Rev. 2/11)



Motion Control Systems